

Visible Fastener Field Drilling Instructions



SUGGESTED DRILLING TOOLS

Do NOT use a hammer drill.

RECOMMENDED FOR ANCHOR HOLES

1/4" Glass/Ceramic/Masonry Bit

RECOMMENDED FOR SMALL HOLES

Bosch GT3000 Glass & Tile Set | 1/8" - 3/4"

Steelex D3731 Glass Cutting Drill Bits | 1/8" - 3/4"

RECOMMENDED FOR LARGE HOLES (Misc. Penetrations)

Hitachi 728792C Carbide Grit for Hole Saw | 2 1/2"

Greenlee 725-4-1/8 Carbide-Grit Hole Saw | 4 1/8"

Amico Pilot Bit Hole Saw Alloy Cutter Kit w/Hex Wrench | 22.5 mm

SAFETY + WORK GEAR

Eye protection is required for all drilling operators.
Material Safety Data Sheets (MSDS) are available upon request.

ENVIRONMENT

Please adhere to all local, state, and federal regulations pertaining to the treatment and discharge of wastewater generated as a result of cutting and drilling TAKTL material. TAKTL is a non-hazardous material for the purpose of wastewater classification. Requirements for treatment of wastewater will be specific to project, site location, and cutting/drilling conditions.

TAKTL panels are typically drilled per approved drawings prior to shipment. However, situations may arise in which field drilling is required. Be prepared to field drill holes and penetrations in TAKTL panels in order to accommodate the following conditions:

- Panels ordered as "field cuts" where building dimensions could not be finalized in advance of drawing submission
- Panels ordered as overage in the event that a project panel was damaged during installation
- Penetrations required for HVAC or electrical building components

Field Cutting + Drilling General Guidelines

NO PENETRATIONS WITHIN 8" OF ANCHOR LOCATIONS

Panel Edge

1/5 PANEL DIM. MAX

8" MAX OR REVIEW REQ.

8" CLR.

Panel Edge

8" MIN

6" MIN

8" MAX OR REVIEW REQ.

8"

2" MAX PENETRATION SIZE AT <8" FROM EDGE OR REVIEW REQUIRED

SETTING UP THE CUT/DRILL PLACEMENT

- Guideline drawing (above) is provided as a general recommendation.
- Anchor quantity and spacing are to be determined by the project engineer or installation contractor per local codes, standards, and environmental conditions.
- Check for anchor hole locations prior to starting cuts.
- Pilot holes recommended for all drilling larger than 1/4".
- Penetrations should be made only with:
 - 8" minimum clearance from any anchor location
 - 2" minimum clearance from edge for any penetrations <2" diameter
 - 8" maximum clearance from edge for any penetrations >2" diameter
 - 6" minimum clearance between penetrations

IMPORTANT



Before Drilling



Wet drilling is required to reduce heat build up, sustain drill bit life, and produce clean holes with the least amount of chatter.



Generally, the tools and techniques used for cutting and drilling stone or ceramics will provide effective results with TAKTL products. Do NOT use a hammer drill.



Remember to maintain all TAKTL handling instructions while staging, moving, thoroughly drying, and storing panels.

01 Securing the Panel

Drill on a large, flat work surface with continuous support to prevent flexing. Do NOT span the panel across unsupported saw horses (FIG. A).

A

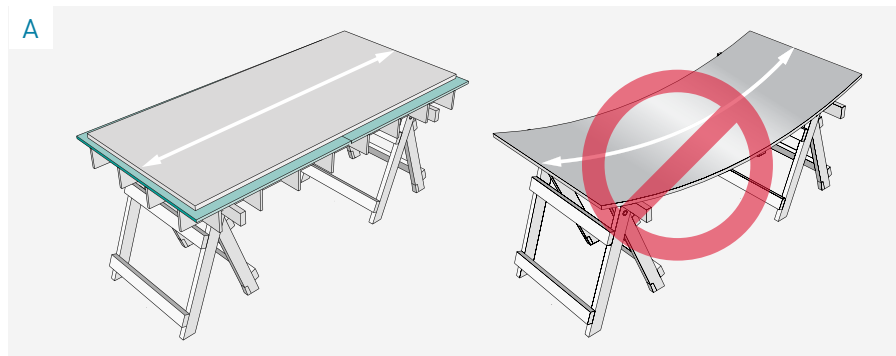

02 Drilling Face Up [Recommended]

Lay the panel face up on the clean foam sheeting provided in shipping crate. Drill from the panel face to rear so any chipping occurs on the back of the panel. Keep the surface uniformly wet while drilling.

NOTE: Hammer function on drill must be DISABLED.

NOTE: Drilling at a slow speed while applying light, constant pressure will reduce the amount of heat generated by friction and maximize the life of the drill bit (FIG. B).

B

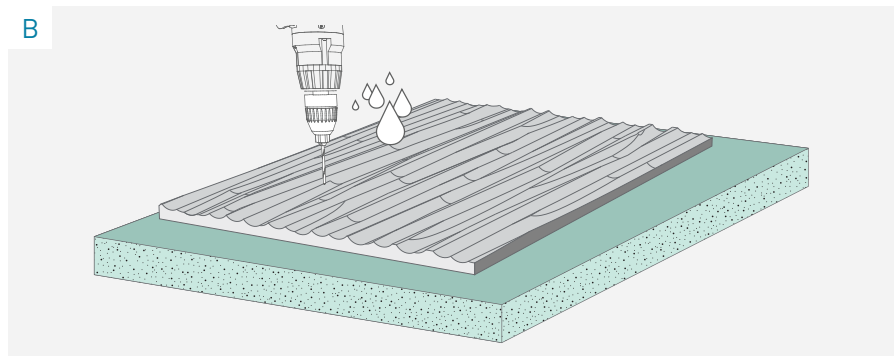

04 Handling the Drilled Panel

Immediately after drilling, rinse the panel surface, wipe completely with a non-abrasive cloth or sponge, rinse, and dry with an air stream from a compressed air gun or electric leaf blower. Improper surface cleaning and drying will result in surface staining, water spotting, or adherence of slurry (FIG. C).

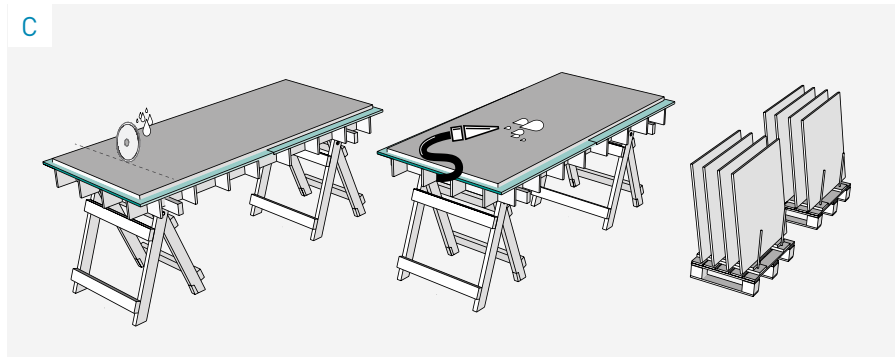

05 Moving Processed Panel

Panels must be carried with the shortest dimension perpendicular to the ground, similar to how glass would be handled (FIG. D).

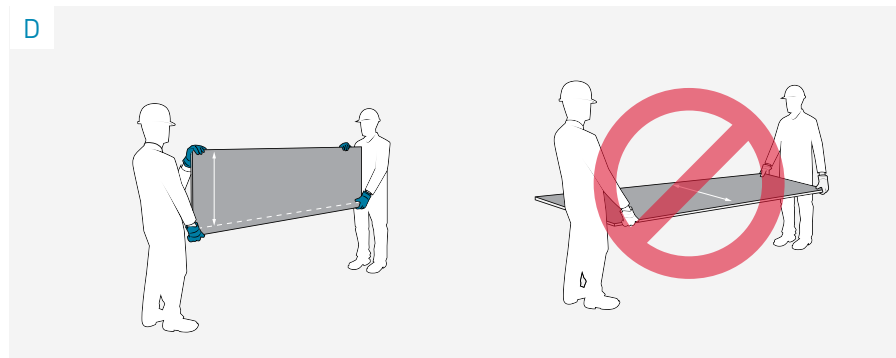

06 Processed Panel Storage

Panels should be stored on edge in a staging rack for ventilated drying. Alternatively, panels may be re-created with original padding (only if completely and evenly dried). Panels should always rest on back edge atop clean foam, provided in shipment, to prevent chipping (FIG. E).

